

Spanbus systemen

Het spanbus systeem koppelt één of twee componenten solide aan/op een aandrijf-as.

De conische vlakken ontwikkelen bij het aandraaien van de bevestigingsbouten een druk tussen as en naaf die een spelingsvrije verbinding creëert.

Eenvoudige montage en demontage.



Type RCK 15

Zelfcentrerend

Geschikt voor samenstellingen waar nauwkeurige axiale en radiale positionering gewenst is in combinatie met een middel-hoog draaimoment.

Bij deze uitvoering wordt gewerkt met een per mm olopende inwendige boring diameter, terwijl de uitwendige diameter slechts 3 verschillende maten kent.

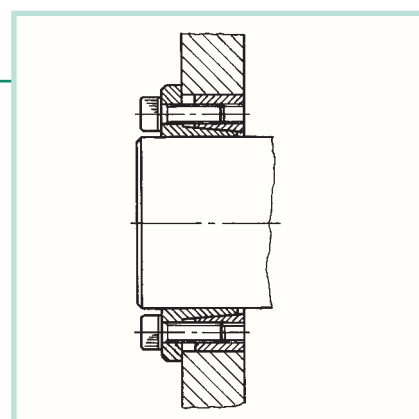

Type RCK 13

Zelfcentrerend

Geschikt voor samenstellingen waar een goede concentriciteit gewenst is binnen kleine afmetingen in combinatie met een middel-hoog draaimoment.

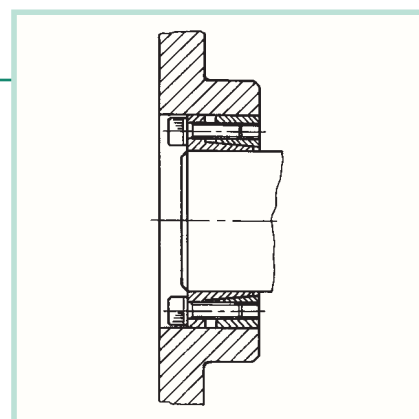

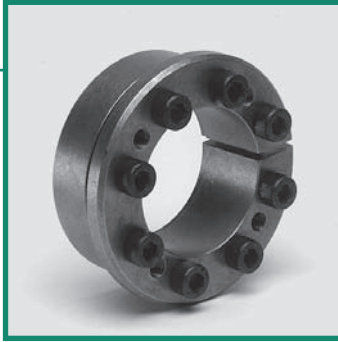

Type RCK 16

Zelfcentrerend

Geschikt voor samenstellingen waar een goede concentriciteit gewenst is in combinatie met een middel-hoog draaimoment.

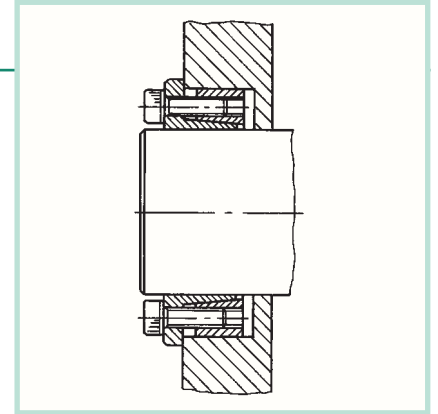

Type RCK 70 / 71 (RCK 70 met spacer)

Zelfcentrerend

Geschikt voor samenstellingen waar concentriciteit en uitgelijnde positionering gewenst is. RCK 71 versie heeft dezelfde eigenschappen als RCK 70 met de aanvulling van een "spacer"-ring die elke mogelijke axiale afwijking elimineert.

Middel-hoog draaimoment.

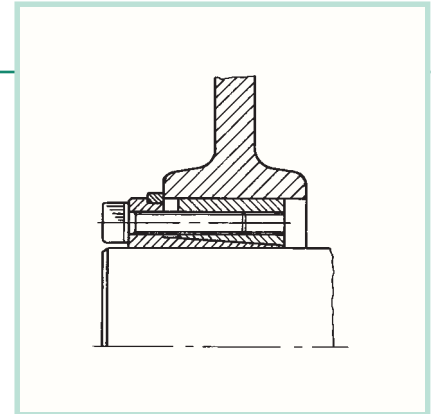

Type RCK 80

Zelfcentrerend

Geschikt voor samenstellingen waarbij de wanddikte van de naaf relatief dun is. Zorgt voor een goede axiale en radiale positionering in combinatie met een middel-hoog draaimoment.

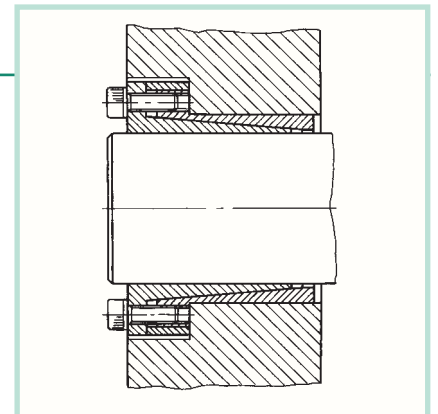

Type RCK 11

Zelfcentrerend

Geschikt voor samenstellingen die onderhevig zijn aan extreem hoge draaimomenten en schokbelasting.

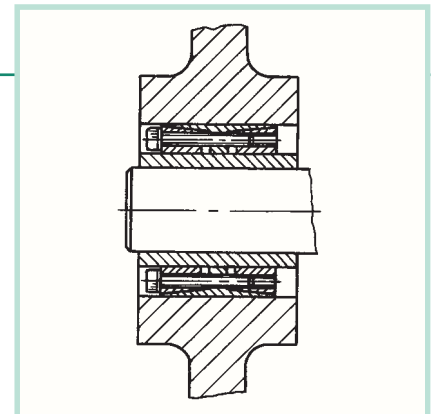

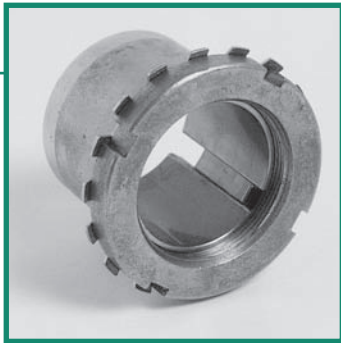

Type RCK 55

Zelfcentrerend

Geschikt voor samenstellingen waarbij sprake is van gelimiteerde maatvoering en een snelle montage gewenst is.

Laag/middel-hoog draaimoment.

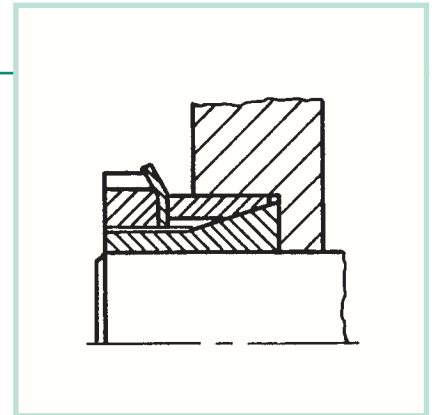

Type RCK 60

Zelfcentrerend

Geschikt voor samenstellingen waarbij een middel-hoog draaimoment nodig is.

Werkt contra aan de RCK 13 uitvoering.

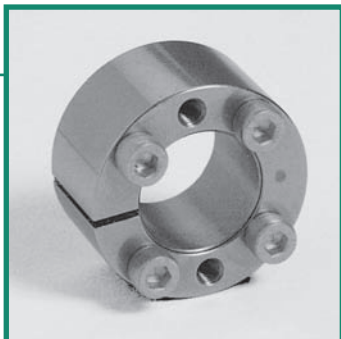
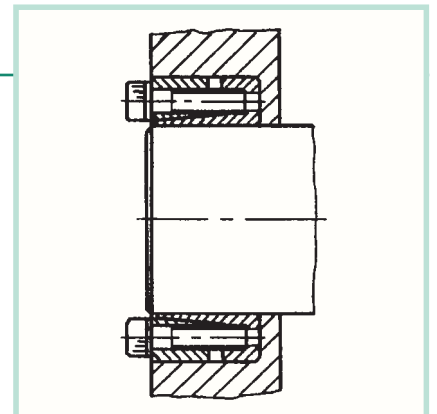

Type RCK 61

Zelfcentrerend

Geschikt voor samenstellingen waarbij het te monteren deel een axiale druk uitoefent tijdens montage.

Middel-hoog draaimoment.

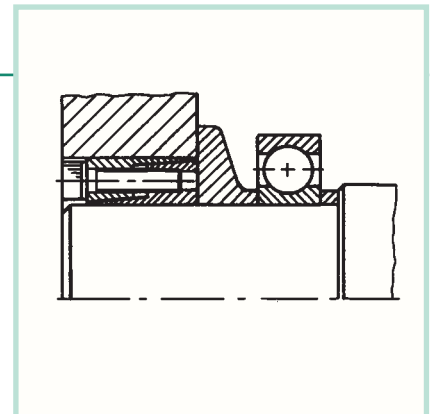

Type RCK 40

Geschikt voor algemene samenstellingen. Is niet zelfcentrerend en dient daarom een aanligvlak te hebben om een goede concentriciteit te realiseren.

Middel-hoog draaimoment.

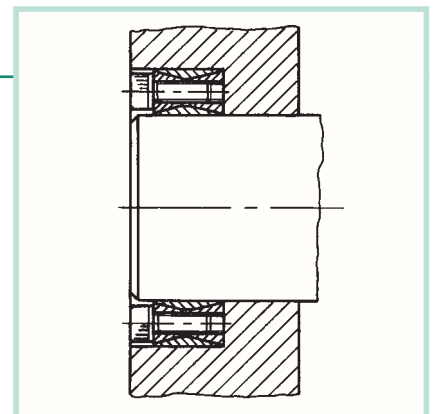



Type RCK 50

Samengesteld uit twee conische ringen, moet altijd worden gemonteerd met een spanmoer. Laag draaimoment.

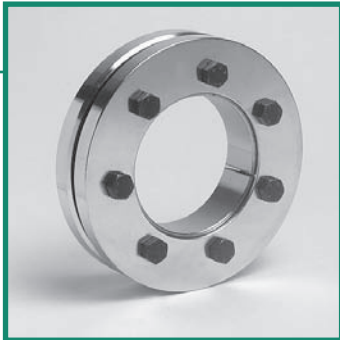
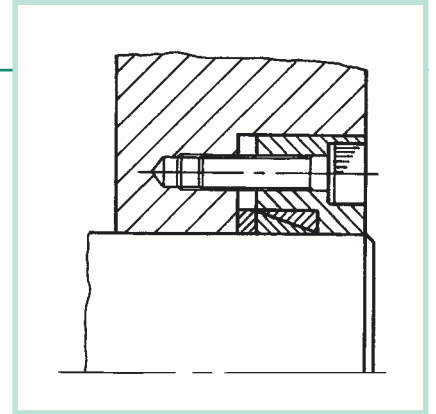

Type RCK 19

Geschikt voor samenstellingen waarbij een holle as wordt vastgeklemd op een massieve as. Middel-hoog draaimoment.

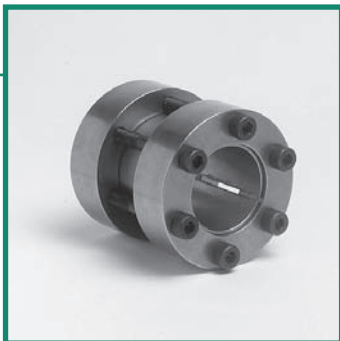
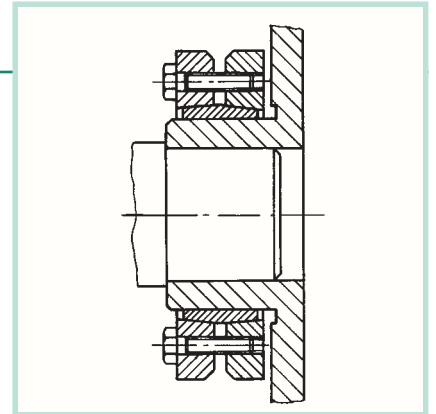

Type RCK 95

Maakt starre verbinding tussen twee uitgelijnde assen. Middel-hoog draaimoment, snelle montage.

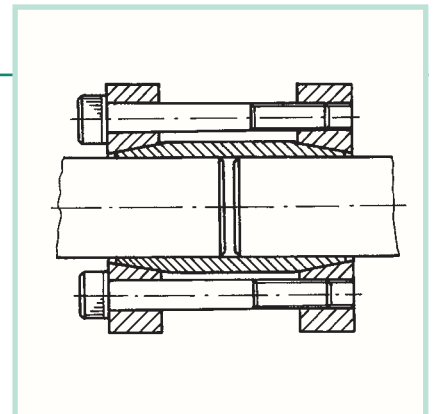

Type RCK 45

Geschikt voor samenstellingen waarbij lage tot middelhoge draaimomenten nodig zijn. Eenvoudige en snelle montage en demontage.

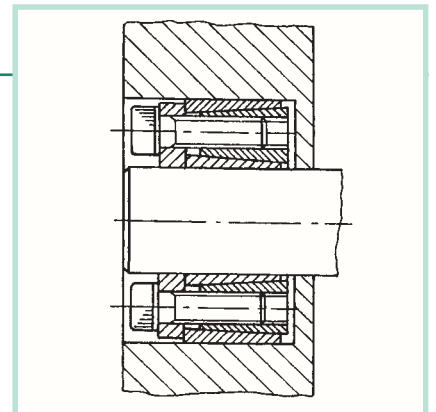

Zelfcentrerend

N.B. De aanbevolen bewerkingstoleranties voor de drukpunten:

as h8

naaf H8

Spanbus type RCK 15

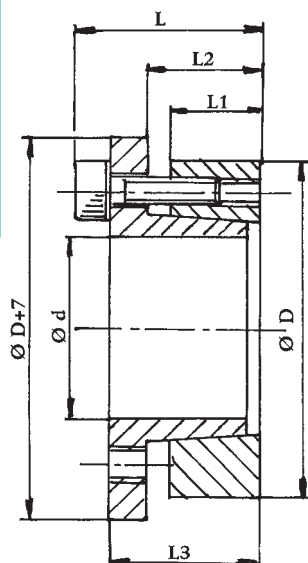

Bestelvoorbeeld

Bij een as met Ød 40 met een as belasting van minder of gelijk aan 1030 Nm wordt gekozen: **RCK 15 - 40x65**.

RCK 15

Ø d	Ø D	Afmetingen				As belasting max. Nm	Druk		Stelschroeven DIN 912 MAT. 12.9			Draad-extractie	
		L1	L2	L3	L		As N/mm ²	Naaf N/mm ²	N.	Type	Aandraai-moment Nm	Type	N.
14	55	17	22	31	39	290	458	118	4	M8x25	41	M8	2
16	55	17	22	31	39	320	400	118	4	M8x25	41	M8	2
18	55	17	22	31	39	360	356	118	4	M8x25	41	M8	2
19	55	17	22	31	39	380	337	118	4	M8x25	41	M8	2
20	55	17	22	31	39	400	320	118	4	M8x25	41	M8	2
22	55	17	22	31	39	440	290	118	4	M8x25	41	M8	2
24	55	17	22	31	39	480	265	118	4	M8x25	41	M8	2
25	55	17	22	31	39	500	255	118	4	M8x25	41	M8	2
28	55	17	22	31	39	560	228	118	4	M8x25	41	M8	2
30	55	17	22	31	39	600	213	118	4	M8x25	41	M8	2
24	65	17	22	31	39	620	332	122	5	M8x25	41	M8	3
25	65	17	22	31	39	640	320	122	5	M8x25	41	M8	3
28	65	17	22	31	39	720	285	122	5	M8x25	41	M8	3
30	65	17	22	31	39	770	267	122	5	M8x25	41	M8	3
32	65	17	22	31	39	820	250	122	5	M8x25	41	M8	3
33	65	17	22	31	39	850	235	122	5	M8x25	41	M8	3
35	65	17	22	31	39	900	228	122	5	M8x25	41	M8	3
38	65	17	22	31	39	980	210	122	5	M8x25	41	M8	3
40	65	17	22	31	39	1030	200	122	5	M8x25	41	M8	3
30	80	20	25	33	41	1080	315	120	7	M8x25	41	M8	3
32	80	20	25	33	41	1150	298	120	7	M8x25	41	M8	3
33	80	20	25	33	41	1200	282	120	7	M8x25	41	M8	3
35	80	20	25	33	41	1260	272	120	7	M8x25	41	M8	3
38	80	20	25	33	41	1370	250	120	7	M8x25	41	M8	3
40	80	20	25	33	41	1440	238	120	7	M8x25	41	M8	3
42	80	20	25	33	41	1510	226	120	7	M8x25	41	M8	3
45	80	20	25	33	41	1620	212	120	7	M8x25	41	M8	3
48	80	20	25	33	41	1730	198	120	7	M8x25	41	M8	3
50	80	20	25	33	41	1800	190	120	7	M8x25	41	M8	3
40	80	20	25	33	41	2150	340	169	10	M8x25	41	M8	4
45	80	20	25	33	41	2420	302	169	10	M8x25	41	M8	4
50	80	20	25	33	41	2700	272	169	10	M8x25	41	M8	4

Zelfcentrerend

N.B. De aanbevolen bewerkingstoleranties voor de drukpunten:

as h8

naaf H8

Spanbus type RCK 13

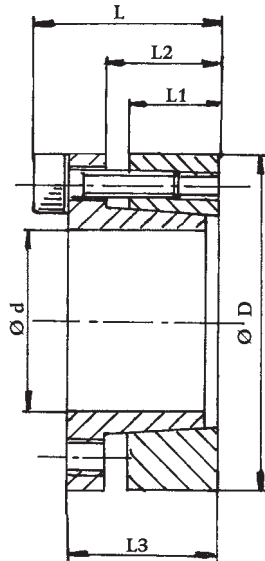

Bestelvoorbeeld

Bij een as met Ød 30 met een as belasting van minder of gelijk aan 650 Nm wordt gekozen: **RCK 13 - 30x55**.

RCK 13

Ø d	Ø D	Afmetingen				As belasting max. Nm	Druk		Stelschroeven DIN 912 MAT. 12.9			Draad-extractie	
		L1	L2	L3	L		As N/mm ²	Naaf N/mm ²	N.	Type	Aandraai-moment Nm	Type	N.
18	47	17	22	28	34	310	314	120	5	M6x20	14	M6	3
19	47	17	22	28	34	330	300	120	5	M6x20	14	M6	3
20	47	17	22	28	34	380	295	125	5	M6x20	14	M6	3
22	47	17	22	28	34	410	270	125	5	M6x20	14	M6	3
24	50	17	22	28	34	440	243	120	6	M6x20	14	M6	3
25	50	17	22	28	34	560	285	140	6	M6x20	14	M6	3
28	55	17	22	28	34	630	255	130	6	M6x20	14	M6	3
30	55	17	22	28	34	660	235	130	6	M6x20	14	M6	3
32	60	17	22	28	34	960	295	155	8	M6x20	14	M6	4
35	60	17	22	28	34	1050	270	155	8	M6x20	14	M6	4
38	65	17	22	28	34	1140	250	145	8	M6x20	14	M6	4
40	65	17	22	28	34	1200	235	145	8	M6x20	14	M6	4
45	75	20	25	33	41	2180	290	170	7	M8x25	35	M8	3
50	80	20	25	33	41	2430	260	160	7	M8x25	35	M8	3
55	85	20	25	33	41	3070	270	175	8	M8x25	35	M8	4
60	90	20	25	33	41	3350	245	165	8	M8x25	35	M8	4
65	95	20	25	33	41	4080	255	175	9	M8x25	35	M8	3
70	110	24	30	40	50	6280	280	180	8	M10x30	70	M10	4
75	115	24	30	40	50	6680	260	170	8	M10x30	70	M10	4
80	120	24	30	40	50	7130	250	160	8	M10x30	70	M10	4
85	125	24	30	40	50	8480	260	180	9	M10x30	70	M10	3
90	130	24	30	40	50	9080	250	170	9	M10x30	70	M10	3
95	135	24	30	40	50	10580	260	180	10	M10x30	70	M10	4
100	145	26	32	44	56	13380	270	190	8	M12x35	125	M12	4
110	155	26	32	44	56	14580	240	180	8	M12x35	125	M12	4
120	165	26	32	44	56	17880	250	180	9	M12x35	125	M12	4
130	180	34	40	52	64	29980	240	170	12	M12x35	125	M12	6
140	190	34	40	54	68	26980	210	150	9	M14x40	190	M14	4
150	200	34	40	54	68	32980	230	170	10	M14x40	190	M14	5
160	210	34	40	54	68	37980	230	170	11	M14x40	190	M14	4
170	225	44	50	64	78	44980	180	130	12	M14x40	190	M14	6
180	235	44	50	64	78	46980	170	130	12	M14x40	190	M14	6

Zelfcentrerend

N.B. De aanbevolen bewerkingstoleranties voor de drukpunten:

as h8

naaf H8

Spanbus type RCK 16

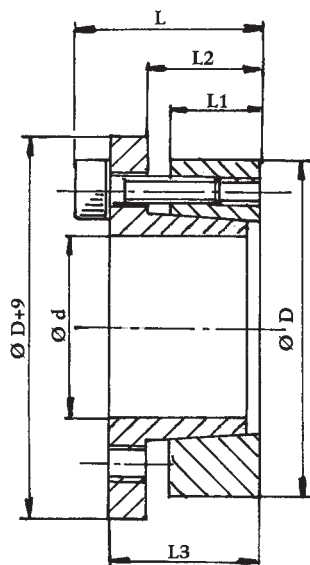

Bestelvoorbeeld

Bij een as met $\text{Ø}d$ 75 met een as belasting van minder of gelijk aan 5000 Nm wordt gekozen: **RCK 16 - 75x115**.

RCK 16

Ø d	Ø D	Afmetingen				As belasting max. Nm	Druk		Stelschroeven DIN 912 MAT. 12.9			Draad-extractie	
		L1	L2	L3	L		As N/mm ²	Naaf N/mm ²	N.	Type	Aandraai-moment Nm	Type	N.
18	47	17	22	28	34	260	240	93	5	M6x20	17	M6	3
19	47	17	22	28	34	270	230	93	5	M6x20	17	M6	3
20	47	17	22	28	34	280	220	95	5	M6x20	17	M6	3
22	47	17	22	28	34	300	200	95	5	M6x20	17	M6	3
24	50	17	22	28	34	400	215	107	6	M6x20	17	M6	3
25	50	17	22	28	34	420	210	105	6	M6x20	17	M6	3
28	55	17	22	28	34	470	190	96	6	M6x20	17	M6	3
30	55	17	22	28	34	500	180	95	6	M6x20	17	M6	3
32	60	17	22	28	34	720	220	115	8	M6x20	17	M6	4
35	60	17	22	28	34	790	200	115	8	M6x20	17	M6	4
38	65	17	22	28	34	850	185	105	8	M6x20	17	M6	4
40	65	17	22	28	34	900	175	105	8	M6x20	17	M6	4
45	75	20	25	33	41	1620	215	125	7	M8x25	41	M8	3
50	80	20	25	33	41	1820	195	120	7	M8x25	41	M8	3
55	85	20	25	33	41	2300	200	130	8	M8x25	41	M8	4
60	90	20	25	33	41	2500	185	125	8	M8x25	41	M8	4
65	95	20	25	33	41	3050	190	130	9	M8x25	41	M8	3
70	110	24	30	40	50	4660	210	135	8	M10x30	83	M10	4
75	115	24	30	40	50	5000	195	125	8	M10x30	83	M10	4
80	120	24	30	40	50	5300	185	125	8	M10x30	83	M10	4
85	125	24	30	40	50	6350	195	135	9	M10x30	83	M10	3
90	130	24	30	40	50	6760	185	130	9	M10x30	83	M10	3
95	135	24	30	40	50	7900	195	135	10	M10x30	83	M10	4
100	145	26	32	44	56	9700	200	140	8	M12x35	145	M12	4
110	155	26	32	44	56	10600	180	130	8	M12x35	145	M12	4
120	165	26	32	44	56	13000	185	135	9	M12x35	145	M12	4
130	180	34	40	52	64	18900	175	125	12	M12x35	145	M12	6
140	190	34	40	54	68	20600	165	120	9	M14x40	230	M14	4
150	200	34	40	54	68	25100	175	130	10	M14x40	230	M14	5
160	210	34	40	54	68	29100	180	135	11	M14x40	230	M14	4
170	225	44	50	64	78	34100	140	105	12	M14x40	230	M14	6
180	235	44	50	64	78	36100	135	105	12	M14x40	230	M14	6

Zelfcentrerend

N.B. De aanbevolen bewerkingstoleranties voor de drukpunten:

as h8

naaf H8

Spanbus type RCK 70

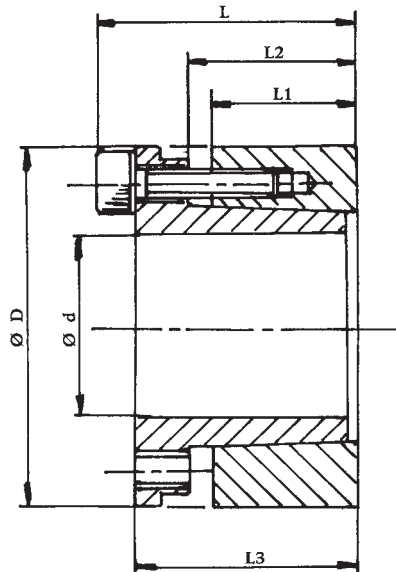

Bestelvoorbeeld

Bij een as met $\text{Ø}d$ 48 met een as belasting van minder of gelijk aan 2510 Nm wordt gekozen: **RCK 70 - 48x80**.

RCK 70

Ø d	Afmetingen					As belasting max. Nm	Druk		Stelschroeven DIN 912 MAT. 12.9			Draad-extractie	
	Ø D	L1	L2	L3	L		As N/mm ²	Naaf N/mm ²	N.	Type	Aandraai-moment Nm	Type	N.
19	47	26	31	39	45	350	228	98	4	M6x25	17	M6	2
20	47	26	31	39	45	390	231	100	4	M6x25	17	M6	2
22	47	26	31	39	45	440	220	95	4	M6x25	17	M6	2
24	50	26	31	39	45	519	215	102	6	M6x25	17	M6	3
25	50	26	31	39	45	590	230	105	6	M6x25	17	M6	3
28	55	26	31	39	45	700	220	110	6	M6x25	17	M6	3
30	55	26	31	39	45	760	200	120	6	M6x25	17	M6	3
32	60	26	31	39	45	930	230	114	8	M6x25	17	M6	4
35	60	26	31	39	45	1030	200	119	8	M6x25	17	M6	4
38	65	26	31	39	45	1240	210	124	8	M6x25	17	M6	4
40	65	26	36	39	45	1350	200	125	8	M6x25	17	M6	4
42	75	30	36	47	55	2170	236	140	6	M8x30	41	M8	3
45	75	30	36	47	55	2350	236	140	6	M8x30	41	M8	3
48	80	30	36	47	55	2510	218	135	6	M8x30	41	M8	3
50	80	30	36	47	55	2580	218	135	6	M8x30	41	M8	3
55	85	30	36	47	55	3200	223	145	8	M8x30	41	M8	4
60	90	30	36	47	55	3380	198	157	8	M8x30	41	M8	4
65	95	30	46	47	55	4160	213	140	8	M8x30	41	M8	4
70	110	40	46	57	67	6840	225	143	8	M10x35	83	M10	4
75	115	40	46	62	72	7500	210	138	8	M10x35	83	M10	4
80	120	40	46	62	72	8100	200	130	8	M10x35	83	M10	4
85	125	40	46	62	72	9700	210	145	10	M10x35	83	M10	4
90	130	40	46	62	72	10300	200	138	10	M10x35	83	M10	4
95	135	40	52	62	72	12100	210	148	10	M10x35	83	M10	4
100	145	46	52	77	89	15700	216	148	8	M12x45	145	M12	4
110	155	46	52	77	89	17200	196	139	8	M12x45	145	M12	4
120	165	46	52	77	89	22500	216	156	10	M12x45	145	M12	4
130	180	46	59	77	89	24000	196	140	12	M12x45	145	M12	4
140	190	51	59	84	90	30800	196	145	8	M14x45	230	M14	4
150	200	51	59	84	90	37150	205	153	10	M14x45	230	M14	5
160	210	51	59	84	90	40500	205	155	10	M14x45	230	M14	5
170	225	51	59	84	90	40900	163	123	12	M14x45	230	M14	6
180	235	51		84	90	41300	160	120	12	M14x45	230	M14	6

Zelfcentrerend

(RCK 70 met spacer)

N.B. De aanbevolen bewerkingstoleranties voor de drukpunten:

as h8

naaf H8

Spanbus type RCK 71

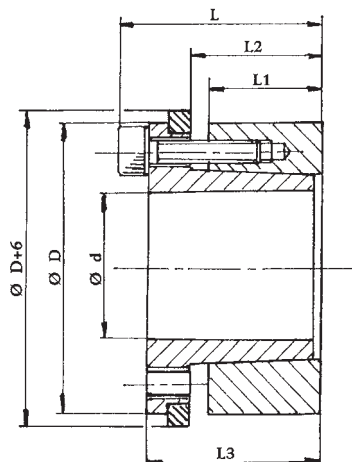

Bestelvoorbeeld

Bij een as met $\varnothing d$ 30 met een as belasting van minder of gelijk aan 650 Nm wordt gekozen: **RCK 71 - 30x55**.

RCK 71

$\varnothing d$	$\varnothing D$	Afmetingen				As belasting max. Nm	Druk			Stelschroeven DIN 912 MAT. 12.9			Draad-extractie	
		L1	L2	L3	L		As N/mm ²	Naaf N/mm ²	N.	Type	Aandraai-moment Nm	Type	N.	
19	47	26	31	39	45	300	228	98	4	M6x25	17	M6	2	
20	47	26	31	39	45	320	231	98	4	M6x25	17	M6	2	
22	47	26	31	39	45	370	211	99	4	M6x25	17	M6	2	
24	50	26	31	39	45	430	220	110	6	M6x25	17	M6	3	
25	50	26	31	39	45	480	226	113	6	M6x25	17	M6	3	
28	55	26	31	39	45	590	207	108	6	M6x25	17	M6	3	
30	55	26	31	39	45	650	226	121	6	M6x25	17	M6	3	
32	60	26	31	39	45	800	201	117	8	M6x25	17	M6	4	
35	60	26	31	39	45	860	206	121	8	M6x25	17	M6	4	
38	65	26	31	39	45	1030	201	124	8	M6x25	17	M6	4	
40	65	26	31	39	45	1130	239	146	8	M6x25	17	M6	4	
42	75	30	36	47	55	1930	221	138	6	M8x30	41	M8	3	
45	75	30	36	47	55	1950	221	138	6	M8x30	41	M8	3	
48	80	30	36	47	55	2180	226	145	6	M8x30	41	M8	3	
50	80	30	36	47	55	2210	226	146	6	M8x30	41	M8	3	
55	85	30	36	47	55	2730	226	146	8	M8x30	41	M8	4	
60	90	30	36	47	55	2910	201	134	8	M8x30	41	M8	4	
65	95	30	36	47	55	3570	211	145	8	M8x30	41	M8	4	
70	110	40	46	57	67	5830	226	145	8	M10x35	83	M10	4	
75	115	40	46	62	72	6330	221	151	8	M10x35	83	M10	4	
80	120	40	46	62	72	6840	202	142	8	M10x35	83	M10	4	
85	125	40	46	62	72	8160	221	161	10	M10x35	83	M10	4	
90	130	40	46	62	72	8670	201	146	10	M10x35	83	M10	4	
95	135	40	46	62	72	10200	191	141	10	M10x35	83	M10	4	
100	145	46	52	77	89	13600	201	151	8	M12x45	145	M12	4	
110	155	46	52	77	89	14870	201	182	8	M12x45	145	M12	4	
120	165	46	52	77	89	19460	221	162	10	M12x45	145	M12	4	
130	180	46	52	77	89	20820	202	146	12	M12x45	145	M12	4	
140	190	51	59	84	90	25410	192	141	8	M14x45	230	M14	4	
150	200	51	59	84	90	30720	202	152	10	M14x45	230	M14	5	
160	210	51	59	84	90	33150	202	152	10	M14x45	230	M14	5	
170	225	51	59	84	90	34000	161	121	12	M14x45	230	M14	6	
180	235	51	59	84	90	34250	157	122	12	M14x45	230	M14	6	

Zelfcentrerend

N.B. De aanbevolen bewerkingstoleranties voor de drukpunten:

as h8

naaf H8

Spanbus type RCK 80

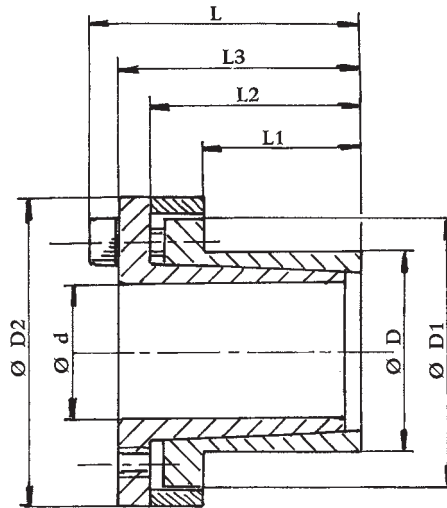

Bestelvoorbeeld

Bij een as met $\text{Ø}d$ 95 met een as belasting van minder of gelijk aan 11000 Nm wordt gekozen: **RCK 80** - 95x120.

RCK 80

Afmetingen								As belasting max. Nm	Druk		Stelschroeven DIN 912 MAT. 12.9			Draad-extractie	
$\text{Ø} d$	$\text{Ø} D$	$\text{Ø} D1$	$\text{Ø} D2$	L1	L2	L3	L		As N/mm ²	Naaf N/mm ²	N.	Type	Aandraai-moment Nm	Type	N.
6	14	22	25	10	18,5	22,5	25,5	12	190	80	3	M3x10	2.2	M3	2
8	15	24	27	12	21,5	25,5	29,5	29	205	110	3	M4x12	5	M4	2
9	16	25	28	14	23,5	27,5	31,5	31	150	85	3	M4x12	5	M4	2
10	16	25	28	14	23,5	27,5	31,5	35	140	85	3	M4x12	5	M4	2
11	18	28	32	14	23,5	27,5	31,5	52	170	105	4	M4x12	5	M4	2
12	18	28	32	14	23,5	27,5	31,5	58	150	100	4	M4x12	5	M4	2
14	23	35	39	14	23,5	27,5	31,5	69	140	80	4	M4x12	5	M4	2
15	24	40	45	16	29,5	36,5	42,5	170	158	98	4	M6x18	17	M6	2
16	24	40	45	16	29,5	36,5	42,5	180	148	98	4	M6x18	17	M6	2
17	26	42	47	19	32,5	39,5	45,5	200	180	125	4	M6x18	17	M6	2
18	26	42	47	19	32,5	39,5	45,5	200	180	125	4	M6x18	17	M6	2
19	27	43	49	19	32,5	39,5	45,5	210	170	120	4	M6x18	17	M6	2
20	28	44	50	19	32,5	39,5	45,5	220	160	115	4	M6x18	17	M6	2
22	32	48	54	26	39,5	46,5	52,5	250	115	80	4	M6x18	17	M6	2
24	34	50	56	26	39,5	46,5	52,5	395	146	102	6	M6x18	17	M6	3
25	34	50	56	26	39,5	46,5	52,5	410	140	102	6	M6x18	17	M6	3
28	39	55	61	25,5	39,5	46,5	52,5	465	135	98	6	M6x18	17	M6	3
30	41	57	62	25,5	39,5	46,5	52,5	510	127	90	6	M6x18	17	M6	3
32	43	59	65	25,5	39,5	46,5	52,5	705	146	108	8	M6x18	17	M6	4
35	47	62	69	31,5	45,5	52,5	58,5	790	105	80	8	M6x18	17	M6	4
38	50	66	72	31,5	45,5	52,5	58,5	860	100	76	8	M6x18	17	M6	4
40	53	69	75	31,5	45,5	52,5	58,5	900	96	72	8	M6x18	17	M6	4
42	55	71	78	31,5	45,5	52,5	58,5	940	90	70	8	M6x18	17	M6	4
45	59	80	86	45	62,5	71	79	1840	110	85	8	M8x22	41	M8	4
48	62	81	87	45	62,5	71	79	2000	105	80	8	M8x22	41	M8	4
50	65	86	92	45	62,5	71	79	2100	100	75	8	M8x22	41	M8	4
55	71	92	98	55	72,5	81	89	2580	85	65	9	M8x22	41	M8	3
60	77	98	104	55	72,5	81	89	2800	75	60	9	M8x22	41	M8	3
65	84	105	111	55	72,5	81	89	3050	70	55	9	M8x22	41	M8	3
70	90	113	119	65	86,5	96,5	106,5	5250	90	70	9	M10x25	83	M10	3
75	95	119	126	65	86,5	96,5	106,5	5600	80	65	9	M10x25	83	M10	3
80	100	125	131	65	86,5	96,5	106,5	8000	100	80	12	M10x25	83	M10	4
85 *	106	131	137	65	86,5	96,5	106,5	8500	95	75	12	M10x25	83	M10	4
90	112	137	144	65	86,5	96,5	106,5	9000	90	75	12	M10x25	83	M10	4
95 *	120	142	149	65	86,5	96,5	106,5	11000	100	80	14	M10x25	83	M10	4
100	125	147	154	65	86,5	96,5	106,5	15000	120	95	18	M10x25	83	M10	4
110	140	172	180	90	114	128	140	16000	80	65	12	M12x35	145	M12	4
120	155	187	198	90	114	128	140	17500	70	55	12	M12x35	145	M12	4

* Op aanvraag

Zelfcentrerend

N.B. De aanbevolen bewerkingstoleranties voor de drukpunten:

as h8

naaf H8

Spanbus type RCK 11

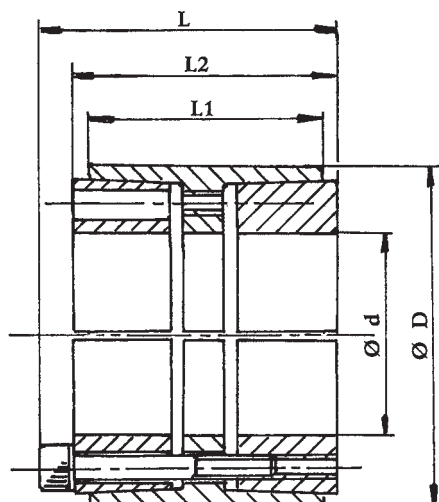

Bestelvoorbeeld

Bij een as met $\text{Ø}d$ 45 met een as belasting van minder of gelijk aan 3200 Nm wordt gekozen: **RCK 11 - 45x75**.

RCK 11

Ø d	Ø D	Afmetingen			As belasting max. Nm	Druk		Stelschroeven DIN 912 MAT. 12.9			Draad-extractie	
		L1	L2	L		As N/mm ²	Naaf N/mm ²	N.	Type	Aandraai-moment Nm	Type	N.
25	55	32	40	46	840	295	134	6	M6x35	17	M6	3
28	55	32	40	46	940	264	134	6	M6x35	17	M6	3
30	55	32	40	46	1000	246	134	6	M6x35	17	M6	3
35	60	44	54	60	1360	174	101	7	M6x45	17	M6	3
38	75	44	54	62	2740	296	150	7	M8x50	41	M8	3
40	75	44	54	62	2880	281	150	7	M8x50	41	M8	3
42	75	44	54	62	3030	268	150	7	M8x50	41	M8	3
45	75	44	54	62	3240	250	150	7	M8x50	41	M8	3
48	80	44	54	62	3950	207	124	8	M8x50	41	M8	3
50	80	56	64	72	4150	200	98	8	M8x50	41	M8	3
55	85	56	64	72	5150	205	104	9	M8x50	41	M8	3
60	90	56	64	72	6200	202	106	10	M8x50	41	M8	4
65	95	56	64	72	6750	187	100	10	M8x50	41	M8	4
70	110	70	78	88	11500	223	114	10	M10x60	83	M10	4
75	115	70	78	88	12300	223	114	10	M10x60	83	M10	4
80	120	70	78	88	14500	215	115	11	M10x60	83	M10	4
85	125	70	78	88	15400	215	115	12	M10x60	83	M10	5
90	130	70	78	88	17800	208	115	12	M10x60	83	M10	5
95	135	70	78	88	18700	208	115	12	M10x60	83	M10	5
100	145	90	100	112	26300	200	107	11	M12x80	145	M12	4
110	155	90	100	112	31800	198	110	12	M12x80	145	M12	5
120	165	90	100	112	40400	212	120	14	M12x80	145	M12	5
130	180	104	116	130	51500	192	112	12	M14x90	230	M14	5
140	190	104	116	130	64700	208	124	14	M14x90	230	M14	7
150	200	104	116	130	74200	208	127	15	M14x90	230	M14	6
160	210	104	116	130	84500	208	128	16	M14x90	230	M14	7
170	225	134	148	164	108200	182	113	14	M16x110	355	M16	6
180	235	134	148	164	123250	184	115	15	M16x110	355	M16	7
190	250	134	148	164	133800	186	116	16	M16x110	355	M16	7
200	260	134	148	164	146000	177	112	16	M16x110	355	M16	7
220	285	134	148	164	181000	188	115	18	M16x110	355	M16	8
240	305	134	148	164	218000	184	119	20	M16x110	355	M16	9
260	325	134	148	164	250000	178	117	21	M16x110	355	M16	10
280	355	165	177	197	360000	185	117	18	M20x130	690	M20	8
300	375	165	177	197	428000	192	123	20	M20x130	690	M20	9

Zelfcentrerend

N.B. De aanbevolen bewerkingstoleranties voor de drukpunten:

as h8

naaf H8

Spanbus type RCK 55

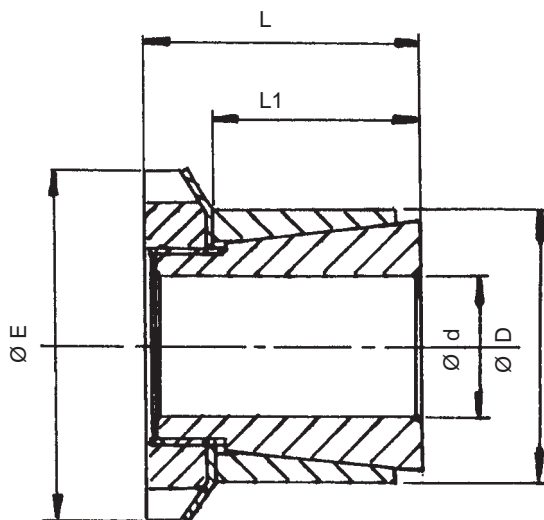

Bestelvoorbeeld

Bij een as met $\text{Ø}d$ 30 met een as belasting van minder of gelijk aan 270 Nm wordt gekozen: **RCK 55 - 30x40**.

RCK 55

Ø d	Afmetingen				As belasting max. Nm	Druk		Verbindingsring type	Schroefdraad	Aandraaimoment Nm	Afsluitring
	Ø D	Ø E	L1	L		As N/mm ²	Naaf N/mm ²				
14	25	32	23	31	65	80	45	KM4	M20x1	95	MB4
15	25	32	23	31	70	80	45	KM4	M20x1	95	MB4
18	30	38	24	33	100	75	45	KM5	M25x1,5	160	MB5
19	30	38	24	33	105	75	45	KM5	M25x1,5	160	MB5
20	30	38	24	33	112	70	45	KM5	M25x1,5	160	MB5
24	35	45	29	38	178	65	45	KM6	M30x1,5	220	MB6
25	35	45	29	38	185	60	45	KM6	M30x1,5	220	MB6
28	40	52	34	44	250	55	40	KM7	M35x1,5	340	MB7
30	40	52	34	44	270	50	40	KM7	M35x1,5	340	MB7
35	45	58	34	45	390	55	45	KM8	M40x1,5	480	MB8
40	50	65	35	46	520	55	45	KM9	M45x1,5	680	MB9
45	55	70	35	47	680	60	50	KM10	M50x1,5	870	MB10
50	60	75	36	48	880	60	50	KM11	M55x2	970	MB11
55	65	80	36	48	1030	60	50	KM12	M60x2	970	MB12
60	70	85	36	50	1360	65	55	KM13	M65x2	1300	MB13

Zelfcentrerend

N.B. De aanbevolen bewerkingstoleranties voor de drukpunten:

as h8

naaf H8

Spanbus type RCK 60

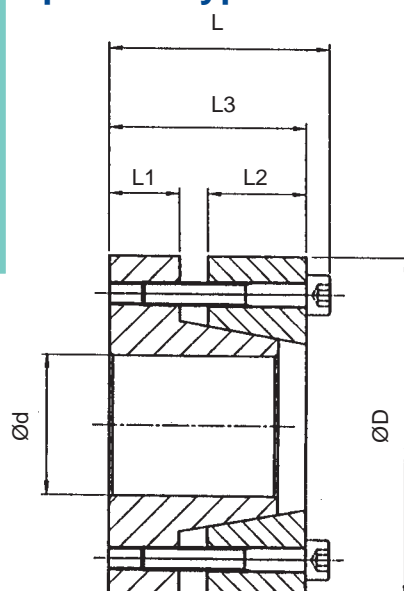

Bestelvoorbeeld

Bij een as met $\varnothing d$ 30 met een as belasting van minder of gelijk aan 480 Nm wordt gekozen: **RCK 60 - 30x55**.

RCK 60

$\varnothing d$	$\varnothing D$	Afmetingen				As belasting max. Nm	Axiale belasting N	Druk		Stelschroeven DIN 912 MAT. 12.9			Draad-extractie	
		L1	L2	L3	L			As N/mm ²	Naaf N/mm ²	N.	Type	Aandraai-moment Nm	Type	N.
20	47	10	14	28	34	245	29400	210	93	5	M6x25	17	M6	3
22	47	10	14	28	34	265	30000	196	93	5	M6x25	17	M6	3
24	50	10	14	28	34	370	32300	215	108	6	M6x25	17	M6	3
25	50	10	14	28	34	390	33300	210	108	6	M6x25	17	M6	3
30	55	10	14	28	34	480	41200	186	98	6	M6x25	17	M6	3
35	60	10	14	28	34	735	44100	186	108	8	M6x25	17	M6	4
38	65	10	14	28	34	790	46100	206	103	8	M6x25	17	M6	4
40	65	10	14	28	34	830	47000	186	103	8	M6x25	17	M6	4
42	75	12	18	35	43	1450	66000	225	132	7	M8x30	41	M8	4
45	75	12	18	35	43	1560	70000	220	132	7	M8x30	41	M8	4
50	80	12	18	35	43	1650	72000	206	127	7	M8x30	41	M8	4
55	85	12	18	35	43	2250	80000	210	132	8	M8x30	41	M8	4
60	90	12	18	35	43	2450	83000	186	122	8	M8x30	41	M8	4
65	95	12	18	35	43	2890	90000	200	132	9	M8x30	41	M8	3
70	110	16	24	46	56	4700	130000	220	140	8	M10x40	83	M10	4

Zelfcentrerend

N.B. De aanbevolen bewerkingstoleranties voor de drukpunten:

as h8

naaf H8

Spanbus type RCK 61

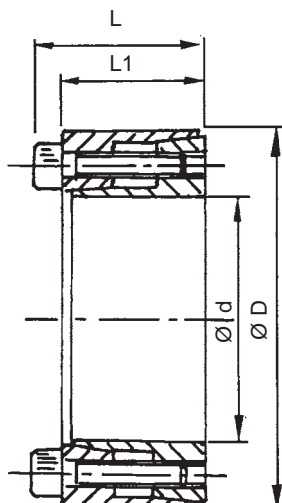

Bestelvoorbeeld

Bij een as met $\varnothing d$ 15 met een as belasting van minder of gelijk aan 40 Nm wordt gekozen: **RCK 61 - 15x28**.

RCK 61

$\varnothing d$	Afmetingen			As be- lasting max. Nm	Druk		Stelschroeven DIN 912 MAT. 12.9			Draad- extractie	
	$\varnothing D$	L1	L		As N/mm ²	Naaf N/mm ²	N.	Type	Aandraai- moment Nm	Type	N.
10	20	13	15,5	15	110	55	4	M2,5x12	1,2	M2,5	2
12	22	13	15,5	20	90	50	4	M2,5x12	1,2	M2,5	2
14	26	17	20	35	105	55	4	M3x16	2,1	M3	2
15	28	17	20	40	100	50	4	M3x16	2,1	M3	2
16	32	17	21	70	130	65	4	M4x16	4,9	M4	2
18	35	21	25	80	115	60	4	M4x20	4,9	M4	2
19	35	21	25	85	110	60	4	M4x20	4,9	M4	2
20	38	21	26	220	220	115	6	M5x20	9,7	M5	3
22	40	21	26	240	200	110	6	M5x20	9,7	M5	3
24	47	26	32	380	220	110	6	M6x25	16,2	M6	3
25	47	26	32	390	210	110	6	M6x25	16,2	M6	3

Zelfcentrerend

N.B. De aanbevolen bewerkingstoleranties voor de drukpunten:

as h9

naaf H9

Spanbus type RCK 40

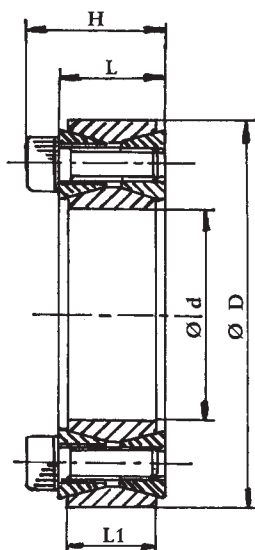

Bestelvoorbeeld

Bij een as met $\text{Ø}d$ 75 met een as belasting van minder of gelijk aan 4900 Nm wordt gekozen: **RCK 40** - 75x115.

RCK 40

Ø d	Ø D	Afmetingen			As belasting max. Nm	Druk		Stelschroeven DIN 912 MAT. 12.9			Draad-extractie	
		L1	L	H		As N/mm ²	Naaf N/mm ²	N.	Type	Aandraai-moment Nm	Type	N.
19	47	17	20	28	255	220	90	8	M6x18	14	M8	2
20	47	17	20	28	270	210	90	8	M6x18	14	M8	2
22	47	17	20	28	300	195	90	8	M6x18	14	M8	2
24	50	17	20	28	360	195	95	9	M6x18	14	M8	3
25	50	17	20	28	380	190	95	9	M6x18	14	M8	3
28	55	17	20	28	500	187	96	10	M6x18	14	M8	4
30	55	17	20	28	530	176	96	10	M6x18	14	M8	4
32	60	17	20	28	630	192	105	12	M6x18	14	M8	4
35	60	17	20	28	700	180	105	12	M6x18	14	M8	4
38	65	17	20	28	860	183	107	14	M6x18	14	M8	4
40	65	17	20	28	910	180	110	14	M6x18	14	M8	4
42	75	20	24	34	1500	226	125	12	M8X22	35	M10	4
45	75	20	24	34	1610	210	125	12	M8X22	35	M10	4
48	80	20	24	34	1700	196	115	12	M8X22	35	M10	4
50	80	20	24	34	1770	190	115	12	M8X22	35	M10	4
55	85	20	24	34	2270	200	130	14	M8X22	35	M10	4
60	90	20	24	34	2470	180	120	14	M8X22	35	M10	4
65	95	20	24	34	3040	190	130	16	M8X22	35	M12	4
70	110	24	28	40	4600	210	130	14	M10x25	70	M12	4
75	115	24	28	40	4900	195	125	14	M10x25	70	M12	4
80	120	24	28	40	5200	180	120	14	M10x25	70	M12	4
85	125	24	28	40	6300	195	130	16	M10x25	70	M12	4
90	130	24	28	40	6600	180	125	16	M10x25	70	M12	4
95	135	24	28	40	7900	195	135	18	M10x25	70	M12	4
100	145	26	33	47	9600	195	135	14	M12x30	125	M14	4
110	155	26	33	47	10500	180	125	14	M12x30	125	M14	4
120	165	26	33	47	13100	185	135	16	M12x30	125	M14	4
130	180	34	38	52	17600	165	115	20	M12x35	125	M14	4
140	190	34	38	52	20900	165	125	22	M12x35	125	M14	4
150	200	34	38	52	24200	170	125	24	M12x35	125	M14	4
160	210	34	38	52	28000	170	130	26	M12x35	125	M14	4
170	225	38	44	60	32800	160	120	22	M14x40	190	M16	4
180	235	38	44	60	37800	165	125	24	M14x40	190	M16	4
190	250	46	52	68	46500	150	115	28	M14x45	190	M16	4
200	260	46	52	68	52500	150	115	30	M14x45	190	M16	5
220	285	50	56	74	68000	150	115	26	M16x50	295	M18	3

Spanbus type RCK 50

N.B. De aanbevolen bewerkingstoleranties voor de drukpunten:

tot $\varnothing d$ 38 mm: as h6 - naaf H7

boven $\varnothing d$ 40 mm: as h8 - naaf H8

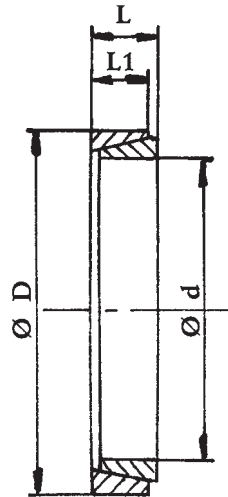

Bestelvoorbeeld

Bij een as met $\varnothing d$ 24 met een as belasting van minder of gelijk aan 73 Nm wordt gekozen: **RCK 50** - 24x28.

RCK 50

$\varnothing d$	Afmetingen			Benodigde kracht kg	As belasting max. Nm	Druk	
	$\varnothing D$	L1	L			As N/mm ²	Naaf N/mm ²
*6	9	3,7	4,5	380	2,4	115	75
*7	10	3,7	4,5	390	3	105	70
*8	11	3,7	4,5	530	4,7	120	90
9	12	3,7	4,5	1560	7,9	140	105
10	13	3,7	4,5	1560	9,5	135	105
12	15	3,7	4,5	1560	11,4	115	90
13	16	3,7	4,5	1560	13,1	110	90
14	18	5,3	6,3	2540	22,3	115	90
15	19	5,3	6,3	2540	24,3	110	85
16	20	5,3	6,3	2540	27,3	105	85
17	21	5,3	6,3	2540	29,8	105	85
18	22	5,3	6,3	2540	32,4	100	80
19	24	5,3	6,3	3600	49	140	110
20	25	5,3	6,3	3600	53	135	105
22	26	5,3	6,3	3600	66	135	115
24	28	5,3	6,3	3600	73	130	110
25	30	5,3	6,3	3600	72	115	95
28	32	5,3	6,3	3600	86	115	100
30	35	5,3	6,3	3600	91	100	85
32	36	5,3	6,3	4500	131	130	115
35	40	6	7	5400	171	125	110
36	42	6	7	5400	169	115	100
38	44	6	7	5400	181	110	95
40	45	6,6	8	6600	231	115	105
42	48	6,6	8	6600	235	110	95
45	52	8,6	10	9900	353	105	95
48	55	8,6	10	13200	572	155	135
50	57	8,6	10	13200	602	150	130
55	62	8,6	10	13200	670	140	125
56	64	10,4	12	15720	790	130	115
60	68	10,4	12	15720	860	125	110
63	71	10,4	12	15720	910	120	105
65	73	10,4	12	15720	950	115	100
70	79	12,2	14	20960	1380	125	110
75	84	12,2	14	20960	1450	115	100
80	91	15	17	29000	2200	125	105

* horizontaal gesneden

Standaard

N.B. De aanbevolen bewerkingstoleranties voor de drukpunten:

diameter $\varnothing d$ h8

Belangrijk:

De interne kegels worden gesmeerd met producten op molybdeen-basis.

Spanbus type RCK 19

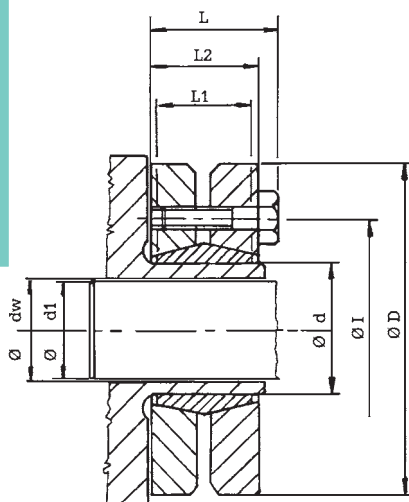

Bestelvoorbeeld

Bij een as met $\varnothing d$ 36 met een as belasting van minder of gelijk aan 440 Nm wordt gekozen: **RCK 19 - 36x72**.

RCK 19

Afmetingen								As be- lasting max. Nm	Druk As N/mm ²	Stelschroeven DIN 931 MAT. 10.9		Aandraai- moment Nm
$\varnothing d$	$\varnothing D$	$\varnothing dw$	L1	L2	L	$\varnothing I$	$\varnothing dw$ ($dw-d1$)			N.	Type	
24	50	19	14	19,5	23	36	0,017	170	286	6	M5x18	4
		20						210			DIN 912 MAT. 12.9	
		21						250				
30	60	24	16	21,5	25	44	0,017	300	233	7	M5x18	4
		25						340			DIN 912 MAT. 12.9	
		26						380				
36	72	28	18	23,5	27,5	52	0,032	440	307	5	M6x20	12
		30						570				
		31						630				
44	80	32	20	25,5	29,5	61	0,032	620	317	7	M6x20	12
		35						780				
		36						860				
50	90	38	22	27,5	31,5	70	0,032	940	289	8	M6x25	12
		40						1160				
		42						1380				
55	100	42	23	30,5	34,5	75	0,032	1160	252	8	M6x25	12
		45						1520				
		48						1880				
62	110	48	23	30,5	34,5	86	0,048	1850	279	10	M6x25	12
		50						2200				
		52						2400				
68	115	50	23	30,5	34,5	86	0,048	2000	255	10	M6x25	12
		55						2500				
		60						3150				
75	138	55	25	32,5	37,8	100	0,048	2500	273	7	M8x30	30
		60						3200				
		65						3950				
80	145	60	25	32,5	37,8	100	0,048	3200	256	7	M8x30	30
		65						3900				
		70						4600				
90	155	65	30	39	44,3	114	0,048	4750	271	10	M8x35	30
		70						6000				
		75						7250				
100	170	70	34	44	49,3	124	0,048	6900	258	12	M8x35	30
		75						7500				
		80						9000				
110	185	75	39	50	56,4	136	0,048	7200	244	9	M10x40	59
		80						9000				
		85						10800				
125	215	85	42	54	60,4	160	0,069	11000	266	12	M10x40	59
		90						13000				
		95						15000				
140	230	95	46	60,5	68	175	0,069	15100	264	10	M12x45	100
		100						17600				
		105						20100				
155	265	105	50	64,5	72	192	0,069	22000	263	12	M12x50	100
		110						25000				
		115						28000				
165	290	115	56	71	81	210	0,069	31000	277	8	M16x55	250
		120						35000				
		125						39000				
175	300	125	56	71	81	220	0,079	36000	261	8	M16x55	250
		130						41000				
		135						45000				
185	330	135	71	86	96	236	0,090	52000	237	10	M16x70	250
		140						57000				
		145						62000				

Starre koppeling

N.B. De aanbevolen bewerkingstoleranties voor de drukpunten:

as h8

Spanbus type RCK 95

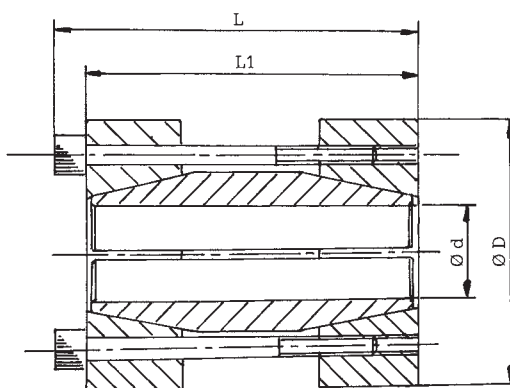

Bestelvoorbeeld

Bij een as met Ød 40 met een as belasting van minder of gelijk aan 900 Nm wordt gekozen: **RCK 95 - 40x75**.

RCK 95

Ø d	Afmetingen			As be- lasting max. Nm	Druk		Stelschroeven DIN 912 MAT. 12.9		
	Ø D	L1	L		As N/mm ²	N.	Type	Aandraai- moment Nm	
17	50	50	56	200	110	4	M6x40	17	
18	50	50	56	220	110	4	M6x40	17	
19	50	50	56	230	110	4	M6x40	17	
20	50	50	56	240	105	4	M6x40	17	
24	55	60	66	290	120	4	M6x50	17	
25	55	60	66	450	110	6	M6x50	17	
28	60	60	66	510	110	6	M6x50	17	
30	60	60	66	550	105	6	M6x50	17	
32	63	60	66	580	90	6	M6x50	17	
35	75	75	83	790	105	4	M8x60	41	
38	75	75	83	850	100	4	M8x60	41	
40	75	75	83	900	95	4	M8x60	41	
42	78	75	83	950	90	4	M8x60	41	
45	85	85	93	1520	110	6	M8x70	41	
48	90	85	93	1620	100	6	M8x70	41	
50	90	85	93	1690	95	6	M8x70	41	
55	94	85	93	2470	110	8	M8x70	41	
60	100	85	93	2710	95	8	M8x70	41	
65	105	85	93	2930	90	8	M8x70	41	
70	115	100	110	3770	90	6	M10x80	83	
*75	125	100	110	4030	80	6	M10x80	83	
*80	125	100	110	4300	70	6	M10x80	83	

* Op aanvraag

Spanbus type RCK 45

N.B. De aanbevolen bewerkingstoleranties voor de drukpunten:
as h8
naaf H8

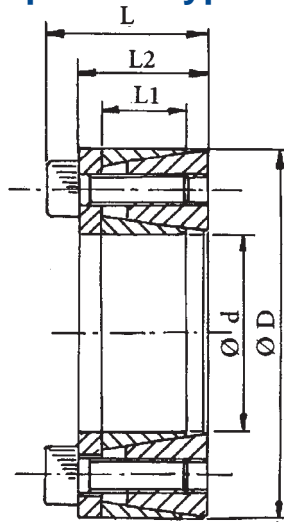

Bestelvoorbeeld

Bij een as met Ød 55 met een as belasting van minder of gelijk aan 2000 Nm wordt gekozen: **RCK 45 - 55x83**.

RCK 45

Ø d	Ø D	Afmetingen			As belasting max. Nm	Druk		Stelschroeven DIN 931 MAT. 10.9			Draad-extractie	
		L1	L2	L		As N/mm ²	Naaf N/mm ²	N.	Type	Aandraai-moment Nm	Type	N.
18	40	12	18,5	24,5	190	260	120	6	M6X16	16	M8	2
19	41	12	18,5	24,5	210	260	120	6	M6X16	16	M8	2
20	42	12	18,5	24,5	240	250	120	6	M6X16	16	M8	2
24	46	12	18,5	24,5	290	250	120	6	M6X16	16	M8	2
25	47	12	18,5	24,5	330	230	120	8	M6X16	16	M8	2
28	50	12	18,5	24,5	370	220	120	8	M6X16	16	M8	2
30	52	12	18,5	24,5	430	210	120	8	M6X16	16	M8	2
35	57	15	22	28	610	170	100	12	M6X16	16	M8	3
38	60	15	22	28	680	170	100	12	M6X16	16	M8	3
40	62	15	22	28	780	170	100	12	M6X16	16	M8	3
42	70	18	28	36	1480	190	110	12	M8X22	41	M10	3
45	73	18	28	36	1500	210	130	12	M8X22	41	M10	3
48	76	18	28	36	1550	210	130	12	M8X22	41	M10	3
50	78	18	28	36	1650	190	120	12	M8X22	41	M10	3
55	83	18	28	36	2000	190	120	16	M8X22	41	M10	4
60	88	18	28	36	2350	190	120	16	M8X22	41	M10	4
70	105	22	35	45	3900	180	120	12	M10X25	70	M12	3
80	115	22	35	45	4800	170	120	16	M10X25	70	M12	4

Spanbus

Controleer de minimale diameter van de naaf Dm

De minimale diameter van de naaf moet worden gecontroleerd nadat de juiste spanbus, geschikt voor het benodigde draaimoment, is geselecteerd. De naaf moet geschikt zijn om door de spanbus gegenereerde kracht op te vangen.

$$D_m \geq D \times \sqrt{\frac{R_{s\ 0.2} + (P_m \times C)}{R_{s\ 0.2} + (P_m \times C)}}$$

- Waar: D_m = buitendiameter naaf (mm)
 D = buitendiameter spanbus (mm)
 $R_{s\ 0.2}$ = vloeigrens voor een permanente verlenging van 0.2% (N/mm²)
 P_m = specifieke druk die wordt uitgeoefend door de spanbus (N/mm²)
 C = correctie factor op basis van naaflengte (zie onderstaande figuren)

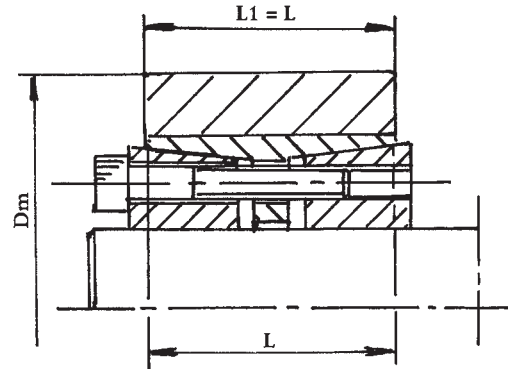
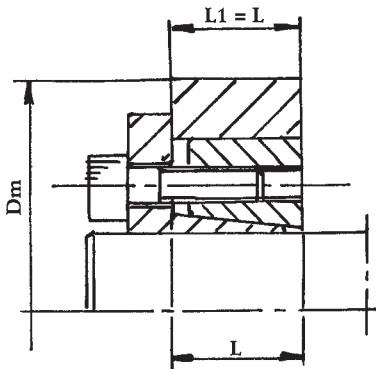

C = 1

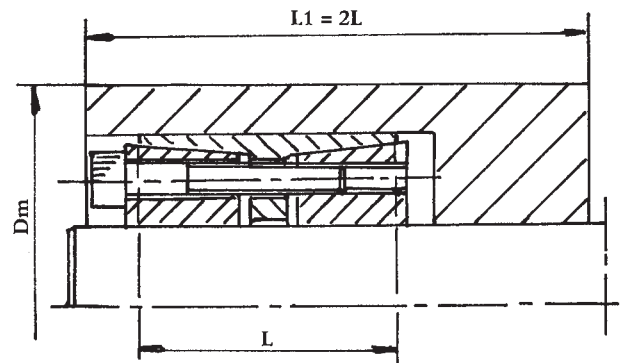
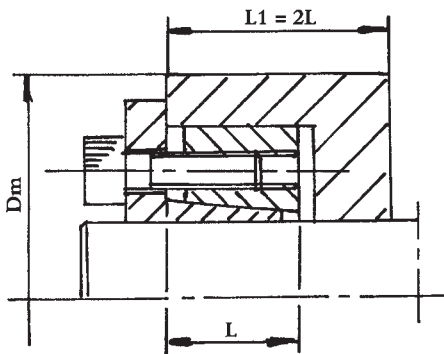

C = 0.8

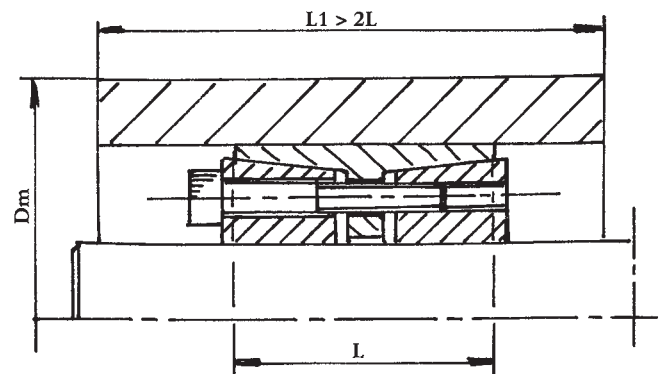
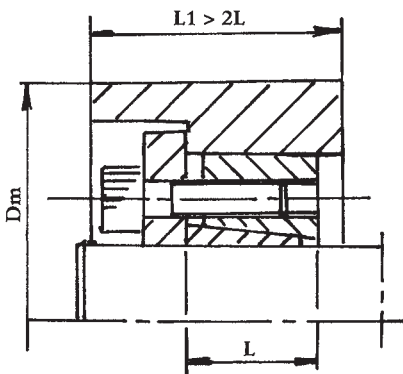

C = 0.6